

**CARACTÉRISTIQUES**

- Machine robuste.
- Tapis en PVC.
- Commande manuelle :  
SM-520F: avec levier.  
SM-520S: avec bouton.
- Vitesse 50 cm/sec.
- Tables relevables.

**FEATURES**

- Robust machine.
- PVC conveyor belts.
- Manual operation:  
SM-520F: with handle.  
SM-520S: with push button.
- Speed 50 cm/sec.
- Tables can be raised after operation.

**EIGENSCHAPPEN**

- Robuste machine.
- PVC transportbanden.
- Handbediening:  
SM-520F: met hendel.  
SM-520S: met drukknop.
- Snelheid 50 cm/sec.
- Opklapbare tafels.



Tables relevables.  
Tables can be raised after operation.  
Opklapbare tafels.

Tapis en PVC.  
PVC conveyor belts.  
PVC transportbanden.



Équipé avec roulettes  
pourvues de frein, facile à déplacer.

Mounted on castors with locking  
system, easily movable.

Uitgerust met zwenkwielen  
met rem, makkelijk te verplaatsen.

**VUE LATÉRALE | SIDE VIEW | ZIJAANZICHT**

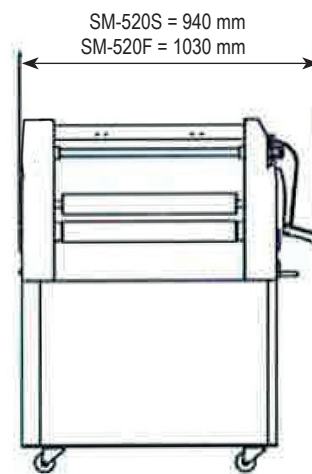

**VUE DE FACE | FRONT VIEW | VOORAANZICHT**

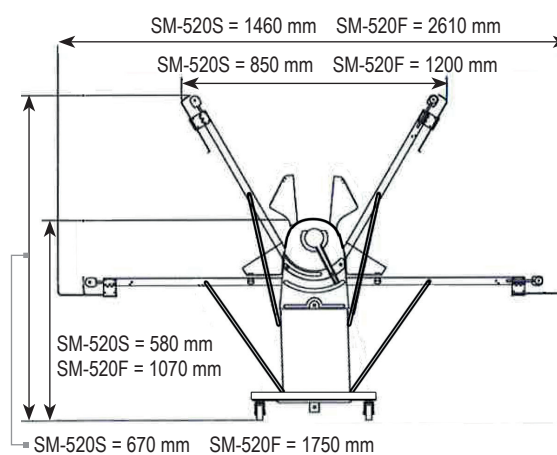

**SM-520S**

**SM-520F**

MODEL	SM-520S	SM-520F
MODÈLE SUR SOCLE   MODEL WITH SUPPORT   SOKKELMODEL	✗	✓
PUISSANCE MOTEUR   MOTOR POWER   MOTORVERMOGEN	0,55 kW	0,55 kW
POIDS NET MACHINE   NET WEIGHT MACHINE   NETTOGEWICHT MACHINE	100 kg	158 kg
LARGEUR DU LAMINAGE   WORKING WIDTH   UITROLBREEDTE	520 mm	520 mm
LONGUEUR DU TAPIS   CONVEYOR BELT LENGTH   LENGTE TRANSPORTBAND	2 x 670 mm	2 x 980 mm
ÉCART ENTRE LES ROULEAUX   SPACE BETWEEN ROLLERS   RUIJTE TUSSEN DE ROLLEN	1 - 30 mm	1 - 30 mm
VOLTAGE   VOLTAGE   SPANNING	220/380V 3Ph 50Hz	220/380V 3Ph 50Hz